

MODEL L77S-20

SERIAL # 2007-8899999

2270 Industrial boul. , Montreal (Laval), Canada, H7S 1P9

Tel.: (450) 667-9769, Fax: (450) 667-6320



INSTRUCTION **MANUAL**

**FOR ALL INQUIRIES
PLEASE CONTACT
OUR LOCAL DISTRIBUTOR**

**FOR NORTH AMERICA ONLY
1-800-333-6556**

Thank you for choosing ORION stretch-wrapping equipment. It is a wise choice, which will benefit your company now and in the future.

ORION uses a unique combination of functional, rugged steel structure and sophisticated control systems to offer equipment high in durability and low in maintenance requirements. Our advance control systems mean that Orion equipment can be operated safely and efficiently without the need for special operator expertise.

Please read this manual carefully and keep it handy. Following these simple operating instructions will insure the safe and efficient performance of this machine while simple maintenance procedures will guarantee a long and productive life of the equipment.

Notice:

Our manual covers standard features of the machine. Certain options may not be fully covered due to their unique application.

In order to acquire more information about custom made features of your machine and to provide quicker service, the following information is required when making an inquiry:

1)Model

2)Serial Number **2007-8899999**

3)Subassembly (see PART LIST)

SAFETY:

ORION'S stretch wrappers should be operated with caution and common sense as any other industrial equipment. To prevent injury and/or electrical shocks, careful operation of the machine and awareness of its many automatic functions is required.

NOTE: All electrical power and compressed air must to be disconnected prior to all inspection, maintenance or repair work.

ORION PACKAGING INC.

ORION PACKAGING SYSTEMS INC. SEMI-AUTOMATIC SPECIFICATIONS

ORION EPIC® SERIES MODEL L-77S

Spiral Semi-Automatic Medium Duty Low Profile w/Surrounding Steel Deck Frame

Maximum Load Size	55"W x 55"L x 84"H
Weight Capacity	4,000 lbs. Dynamic, 20,000 lbs. Static
Utilities	115 / 1 / 60 ; 15 Amp Service
Turntable	59" Diameter Structural Steel Plate Dura-Glide™ Turntable Support System, Quiet in Operation, Maintenance Free 3" Height Floor to Top of Turntable
Turntable Drive	0-12 RPM Variable Turntable Speed Variable Speed Drive Motor Heavy Duty Chain Drive with Tensioner Electronically Adjustable Acceleration/Deceleration (Soft Start) Positive Alignment Feature
Control Features	CSA Approved, NEMA 12 Control Panel State-of-the-Art Logic Control User Friendly Microprocessor with Micro-Switch Keypad Revo-Logic™ Exact Wrap Counting Technology Electronic Film Tension Control Adjustment on the Panel Separate Top Bottom Wrap Count Selectors with LED Count Display Variable Speed Film Carriage Up/Down Control Film Carriage Raise/Lower Switch (Manual) Photocell for Automatic Load Height Detection Turntable Jog Pushbutton
Film Delivery	20" Insta-Thread LT Powered Pre-Stretch Film Delivery System 200% Pre-Stretch Ratio Easy & Safe to Operate Self-Threading Carriage Design Electronic Film Tension Control Adjustment on the Panel Variable Speed Film Output (Non-Wearing Sensor) Heavy Duty Chain & Sprocket Ratio Control Adjustable Film Roping Bar on Chassis for Stronger Interlocking of Load and Pallet
Film Carriage Elevator Drive	Heavy Duty ANSI Chain Carriage Lift Variable Speed Drive Motor Multi-Point UHMW Precision Carriage Guidance System
Structural Features	100% Structural Steel Construction Throughout Easy Access to All Components Open Mechanical Design for Ease of Maintenance Forklift Portable Base Design Structural Steel Tube Mast Design Hinged Mast for Ease of Shipping, Portability
Estimated Shipping Weight	1,500 lbs.

Visit our Distributor Support Website at www.support.orionpackaging.com

MACHINE UNLOADING INSPECTION & INSTALLATION

UNLOADING

Machine can be easily unloaded and transported by a forklift with a minimum capacity of 2500 lbs.

1. Carefully insert the forks into the lifting tubes to the maximum possible depth. Depending on the model, a forklift access may be either at the turntable end of the machine frame, the tower end or both. In case of the mongoose machine enter the forks under the frame or insert the forks in the tube brackets welded to the top of the machine.

2. Lift the machine (or other part of system) only to the necessary height to move it with no bouncing or friction on the floor.

3. Sit the machine down assuring uniform contact with the floor, which is necessary to ensure correct and smooth operation.

INSPECTION

1. Remove all packing and supporting additions - these may include the blocks under the carriage and the restraining bar over the table.

NOTE: when removing the stretchwrap film covering the machine, care must be taken not to cut any of the electrical wires and/ or polyurethane covering on the film carriage rollers.

2. Perform a visual inspection of the electrical and mechanical parts for loosened joints and / or broken connections. Any suspected shipping damage must be reported immediately to the freight carrier. Any transport damage cannot be claimed to Orion Packaging Inc.

Items that are vulnerable to damage and must be inspected are as follows:

- Motors and transmissions
- Junction boxes
- Electrical conduits
- Proximity and limit switches
- Photocells

3. Check under the turntable to ensure that there is no crippling of the movable parts i.e. casters, center axle or drive assembly.

4. Verify the following:

- Turntable or rotary arm drive system to confirm that the reducer to drive the chain is snug and properly aligned.
- Verify the wires tight conduits for crushed sections or loose fittings.

- Verify the film carriage to be sure that it is correctly aligned with the tower
- Verify the tension on the lift chain.
- Verify all the dials and knobs on the control panel for smooth action.

MACHINE INSTALLATION

After the visual inspection has been completed, the electrical power and the compressed air shall be connected as specified on the diagrams supplied with the machine. An electrical diagram is provided with each machine in the envelope attached to the panel box.

ASSEMBLY PROCEDURE

The structural frames of the machine have to be installed on a leveled floor. Locate the main wrapper section into its final position, keeping the tower assembly* away from any traffic. The wrapper mainframe section **must be bolted to the floor by the 1/2" concrete floor anchors** (leg & shield or expandable type).

Any wiring that has been disconnected to facilitate transport is marked with a number located on the junction box to which the wiring must be reconnected. Any wire run that appears too short or long may indicate that the position of the mechanical components is incorrect. Verify the status of all assemblies before proceeding.

* The tower deviation from vertical must not exceed 1/4" on the distance of 10 feet (angle: 0 degrees 6').

CONTROL PANEL

In the case of the free standing panel (console) place it adjacent to the system and anchor firmly to the floor. Connect the liquid tight (rigid conduit) to the main junction box located on the wrapper main frame next to the tower.

Before Starting Machine Operation

Verify that the machine is properly connected to the electrical source. The electrical requirements depend on the machine type and features. For this information, please see the machine electrical diagram provided with the machine operation manual. The control panel layout for the machine is shown on the drawing.

CAUTION: Before preceding the machine operation familiarize yourself with the **EMERGENCY-STOP** button and all functions, switches and pushbuttons.

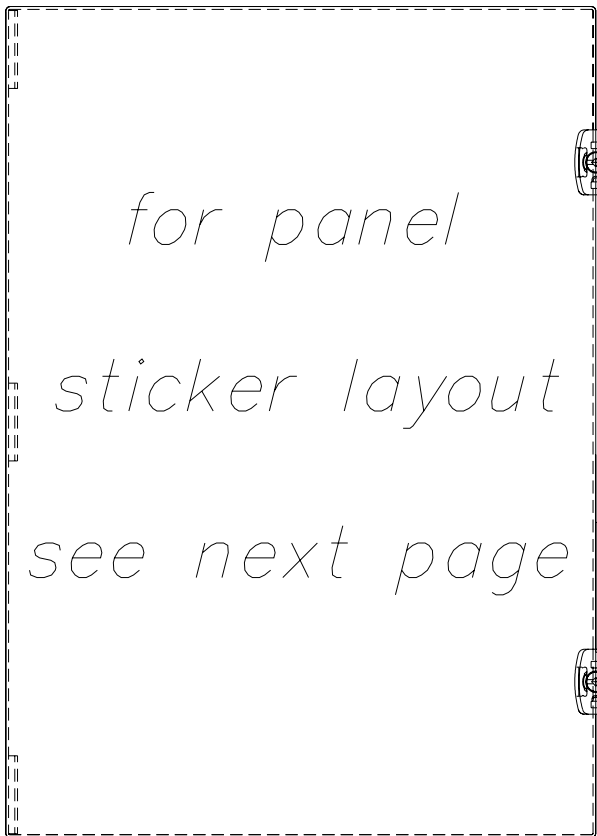

FRONT PLATE

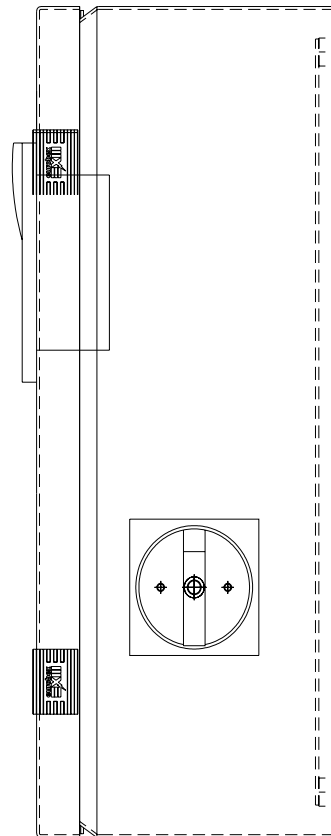

5412 ESCH 16x12x06

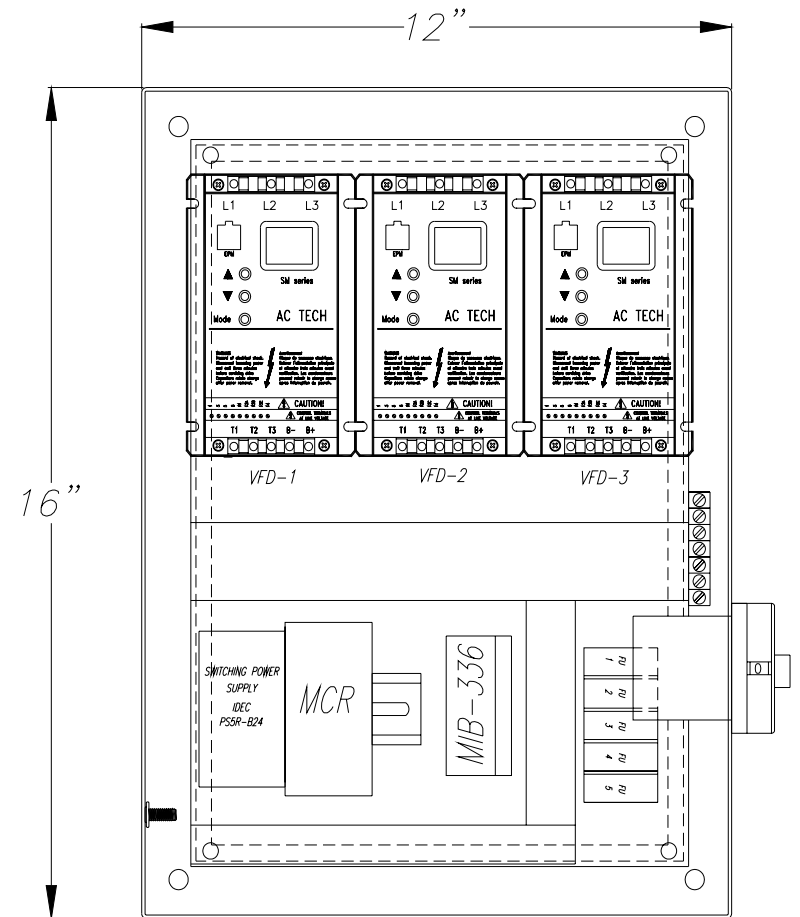

BACK PLATE

 ORION PACKAGING INC. 2270 INDUSTRIEL BOUL., LAVAL QUEBEC, CANADA, H7S 1P9 TEL: (450) 667-9769	2270 INDUSTRIEL BLVD LAVAL, QUE., CANADA H7S 1P9 TEL: (450) 667-9769 FAX: (450) 667-6320 APPR. BY: J.B.S. DRAWN BY: J. ALEXANDER		SCALE: 1:4
	TITLE: HL77-20 "STANDARD"		
	SIZE: B	DOCUMENT NO: 303 318/L JOB # STD	REV: 2
	DATE: NOV-01-2006 FILENAME: H77-ZOL.DWG	SHEET: 1 OF 1 BASE:	

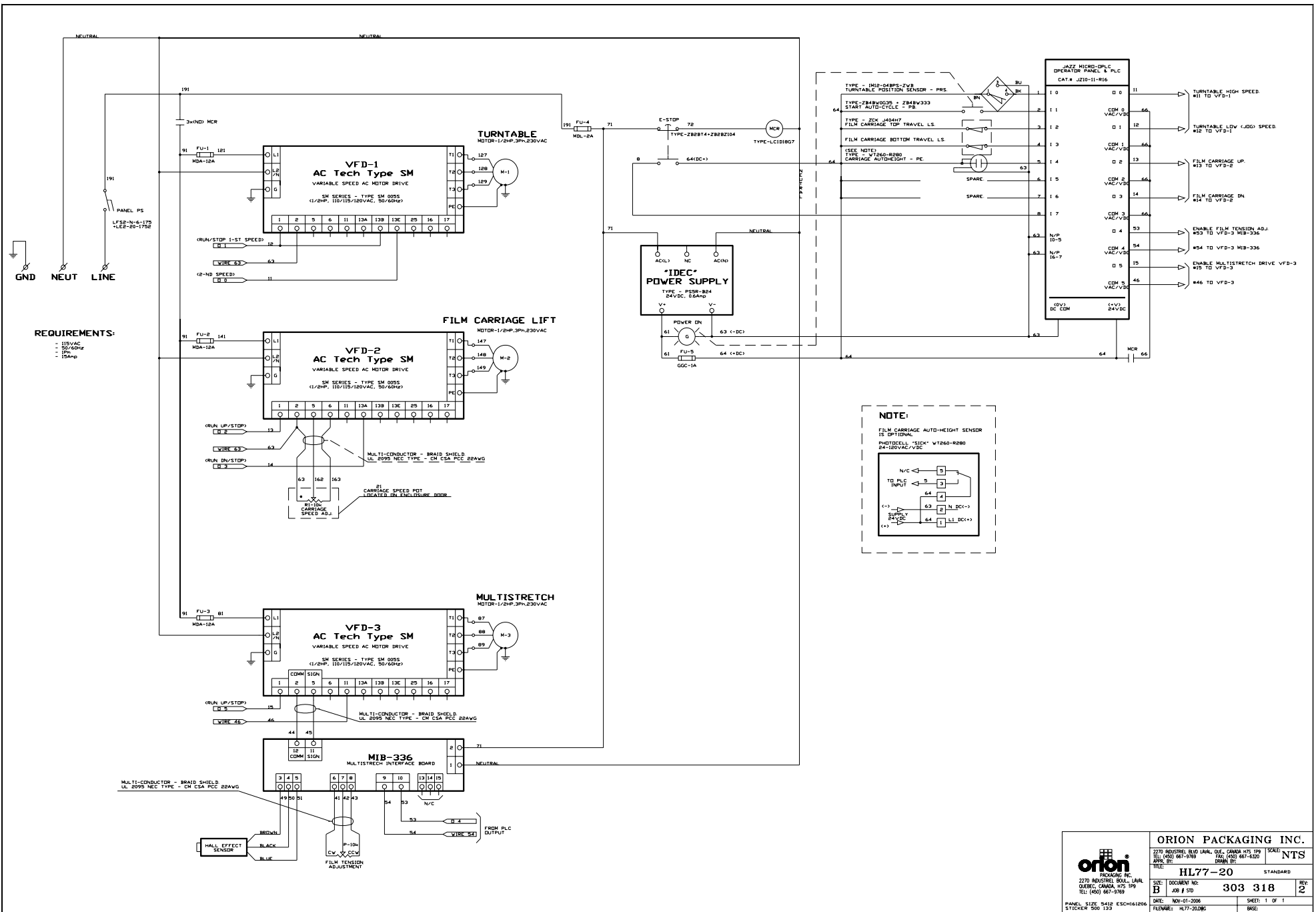

Note: For VFD adjustment, please contact Orion Packaging service department.

		ORION PACKAGING INC.	
		2270 INDUSTRIAL BLVD LAMAR, QUE. CANADA H7S 1P9 TEL: (450) 667-9789 FAX: (450) 667-6300 APPL. BY: TITLE: DRAWN BY:	SCALE: NTS
PACKAGING INC. 2270 INDUSTRIAL BLVD LAMAR QUEBEC, CANADA H7S 1P9 TEL: (450) 667-9789		DOCUMENT NO: 303 318	SHEET: 1 OF 1
PANEL SIZE: 9x12 KSC#H61806 STICKER: 500 120		DATE: NOV-01-2006 FILENAME: H77-20.DWG	SHEET: 1 OF 1 BKG:

START



STOP

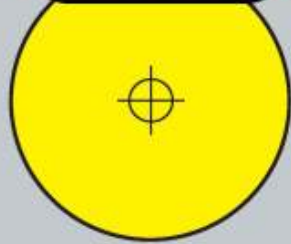

FILM TENSION

CARRIAGE SPEED UP & DOWN

<p>1 TOP WRAPS ▶ T (1-9)</p> <p>2 BOTTOM WRAPS ▶ B (1-9)</p> <p>3</p> <p>4 AUTOHEIGHT EYE ▶ 4 (off/on)</p> <p>5 FILM TENSION ▶ 5 (Lo/Hi) / (Adj)</p> <p>6 WRAP ORDER ▶ 6 { c- Top First d- Bottom First</p>	<p>7 TABLE JOG</p> <p>8</p> <p>9</p> <p>0 PAUSE / RESET</p> <p>▶ CARRIAGE JOG UP</p> <p>▶ CARRIAGE JOG DOWN</p>
--	---

WARNING! DISCONNECT POWER TO THE MACHINE BEFORE OPENING THE PANEL. DANGEROUS OR FATAL ELECTRIC SHOCKS MAY RESULT IF POWER TO THE MACHINE IS NOT DISCONNECTED BEFORE OPENING THE PANEL.

PN 500 143

MACHINE OPERATION

POWER SWITCH

Located on the panel door or side of the panel box, the lockable power switch has two settings:

- ON - connects a power source to the machine
- OFF - disconnects the power source.

START AND EMERGENCY STOP SWITCHES

The START switch is used to start the cycle once the load is on the turntable. The cycle may be stopped at anytime by pressing the STOP button. (see **Figure 1**)



Figure 1

NOTICE: The STOP button interrupts the entire machine electrical circuits. To continue the cycle the STOP push/pull button should be pulled out and START button pressed for the machine to restart. Double pressing the push – pull STOP button will reset the machine program and machine will be ready to apply the wrapping cycle from the beginning.

SETTING-UP MACHINE PARAMETERS

Note: Parameter change is available when machine is not in cycle.

1- TOP WRAPS 1,2,3...9

Press button #1 on the keypad to select “Top Wrap”, then using the arrows on the keyboard select between 1 to 9 for required number of wraps on top of the load.

2- BOTTOM WRAPS 1,2,3...9

Press button #2 on the keypad to select “Bottom Wrap”, then using the arrows on the keyboard select between 1 to 9 for required number of wraps at the bottom of the load.

Note: Refer to the list of options at the bottom of the panel sticker for reference. (see **Figure 3**)



Figure 2

3- NOT USED

4- AUTOHEIGHT EYE

Press button #4 on the keypad to switch from ON to OFF, or vice-versa.(see **Figure 2**)

ON - When ON, the photocell is activated to automatically detect top of the load. The carriage will automatically stop at the top of the load regardless of its height.

OFF - When OFF, the photocell is inoperative and carriage will travel to the top limit switch regardless of its height.

NOTE: For proper machine operation, top limit switch position should be adjusted to desired level prior to starting the cycle.

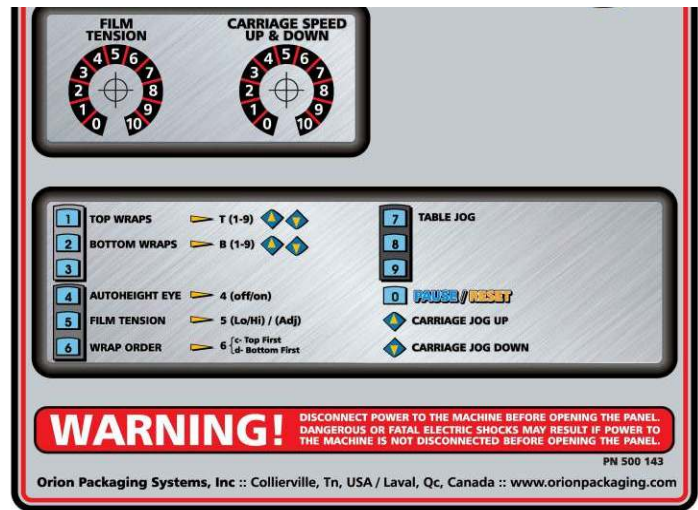

Figure 3

5- FILM TENSION

(High/Low tension switching button #5 is not applicable on this model, this is exclusive function on L77e models)

Film tension may be adjusted using the film tension control knob (see **Figure 4**). The range of tension is from 0 to 10 (0 to 4 the low range, 4 to 8 the most selected range for most of the films used by our customers, 8 to 10 as a very high range which may break some types of films).

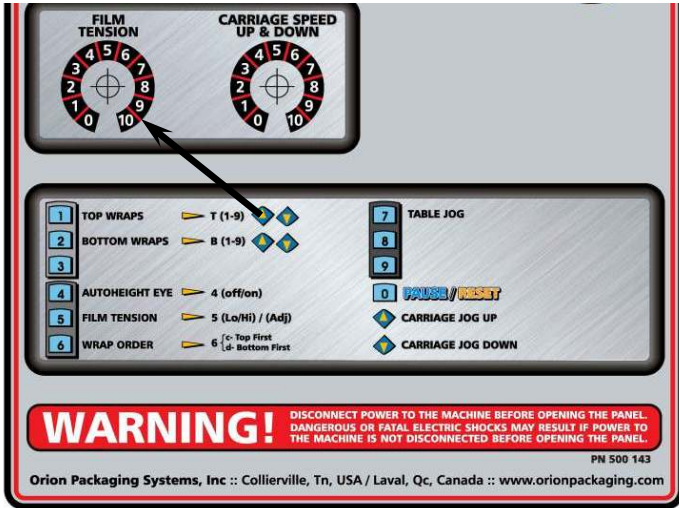

Figure 4

6- WRAPPING ORDER ; TOP FIRST OR BOTTOM FIRST

Press button #6 on the keypad to switch from **BOTTOM WRAPS FIRST** to **TOP WRAPS FIRST**, or vice-versa.

TOP WRAPS FIRST - When this Sub-Mode has been selected film carriage will move to top of load and stop. Selected number of top wraps will be applied. The film carriage will then move to bottom of the load and stop. Selected number of bottom wraps will then be applied. The film carriage will remain in bottom position; turntable will slow down and stop in home position.

BOTTOM WRAPS FIRST - When this Sub-Mode has been selected machine will first wrap bottom of load applying selected number of bottom wraps. The film carriage will then move to top of load and stop. Selected number of top wraps will then be applied. The film carriage will move down to bottom position, after which the turntable will slow down and stop in home position.

7- TURNTABLE JOG

The turntable jog can operate only when machine is not in cycle. The turntable jog will rotate at a low speed when the button #7 is held down, when released, the turntable will stop.

CARRIAGE SPEED (Film Overlap)

The carriage speed knob can be used to control the amount of film overlap apply during the wrap. The potentiometer has settings from 0 to 10, the higher the settings the faster the speed.

High settings apply less film overlap due to faster carriage speed. Low settings apply more film overlap due to lower carriage speed. (**Figure 5**)

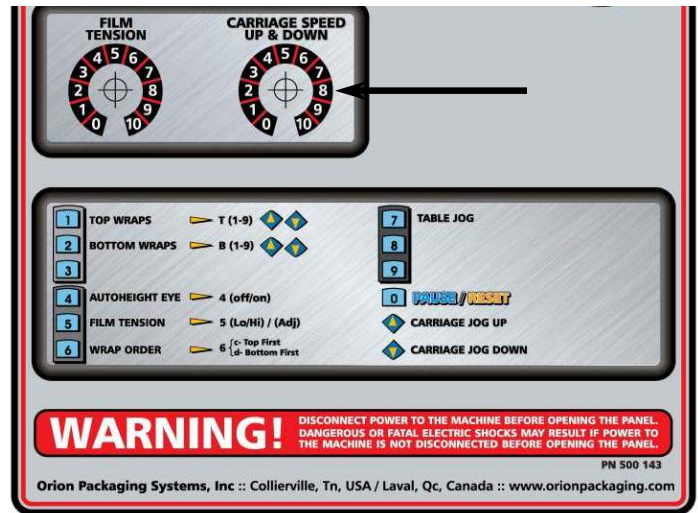

Figure 5

MACHINE WRAPPING TEST

Notice: It is advisable to test-run the equipment with several pallet loads before attempting to wrap using film. Please position the operator beside the EMERGENCY STOP push button. Start up of the machine (system) may determine the need for the adjustment of:

- Load height stop photoswitch (on the carriage)
- Top limit switch position
- Bottom limit switch position
- Roping bar height adjustment

Before the test procedures adjust the wrapping cycle parameters i.e. top wraps, bottom wraps, height photocell on/off, film tension, carriage speed (Last two parameters may be adjusted during the wrapping cycle).

LOADING THE FILM

The film roll can be loaded on the carriage mandrel from either end of the roll. When using tacky film, please verify that the tacky surface of the film is inward on the load.

1. Disconnect power (turn off power switch).
2. Swing up the top mandrel spool.
3. Put the roll of film on the bottom mandrel.
4. Install the top mandrel on top of the roll to prevent upward movement.
5. Pull the handle marked PULL TO OPEN to open film distributor cradle.
6. Pass the roped tail of the film through opening (as shown on the film quick threading pattern DWG. # 418180 Fig.1).
7. Close the film distributor cradle by pushing bar marked PUSH TO CLOSE.
8. When the film feeding is completed (fig. 2) – turn the power switch on.
9. Peel off the first few winds of the film (multistrech will run due to displacement of the dancer roller) and fix the film end onto the load.

The system is now ready to begin the first wrapping cycle.

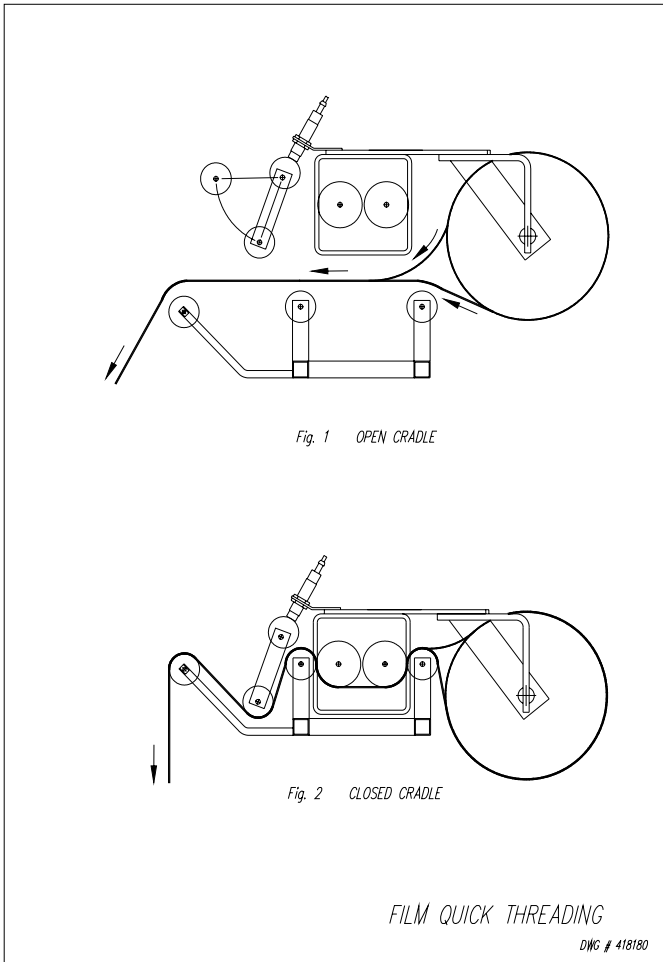

ADDITIONAL SPACER WASHER

(IF NEEDED ONLY)

The roll of film may be slightly different from time to time, so you might have to change the bottom spool spacer (washer). The only thing you have to do is to add or remove the spacer washer under the bottom spool. With the machine there is 1 washer under the bottom spool (432322), and you have received with the machine 2 extra washer to be use if needed.

Note: The bottom of the film should not be lower than the chamfer of the aluminum strip as shown on the drawing below.

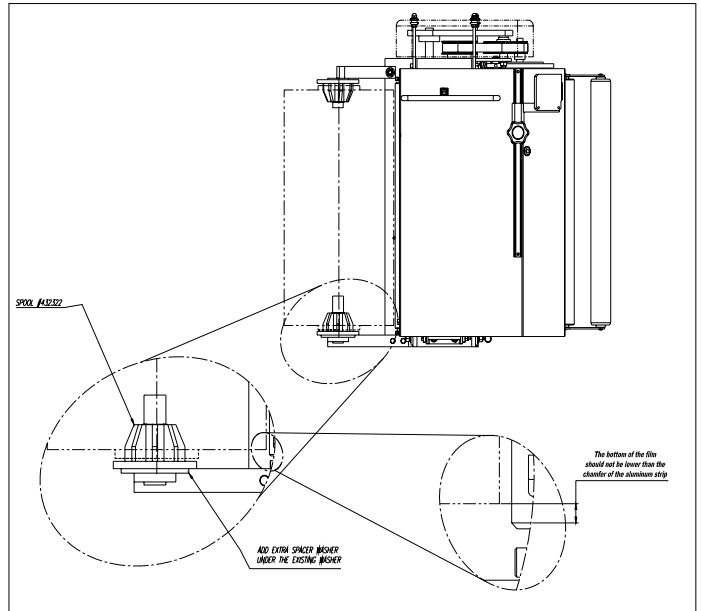

PROXIMITY SENSOR ADJUSTMENT

Occasionally the Feed Back Proximity Sensor may need some adjustment. The position of the feed back proximity sensor against the cam is shown on drawing # 419139 and on **Figure 6**.

Adjustment instructions:

- Power down machine.
- Remove the carriage cover.
- Unbolt the two nuts holding the proximity switch - item # 1.
- Turn the Proximity sensor - (item # 2) to create the gap between the cam and the front side of proximity sensor about 1/8 ".
- Tighten on the nuts securing the Proximity Sensor.
- Put the cover back on.
- Power up machine.
- Turning the trim pot SPAN adjust the moment when motor starts to turn when dancer roller moved from its home position up to 1 1/2".
- If not satisfied repeat the procedure.



Figure 6

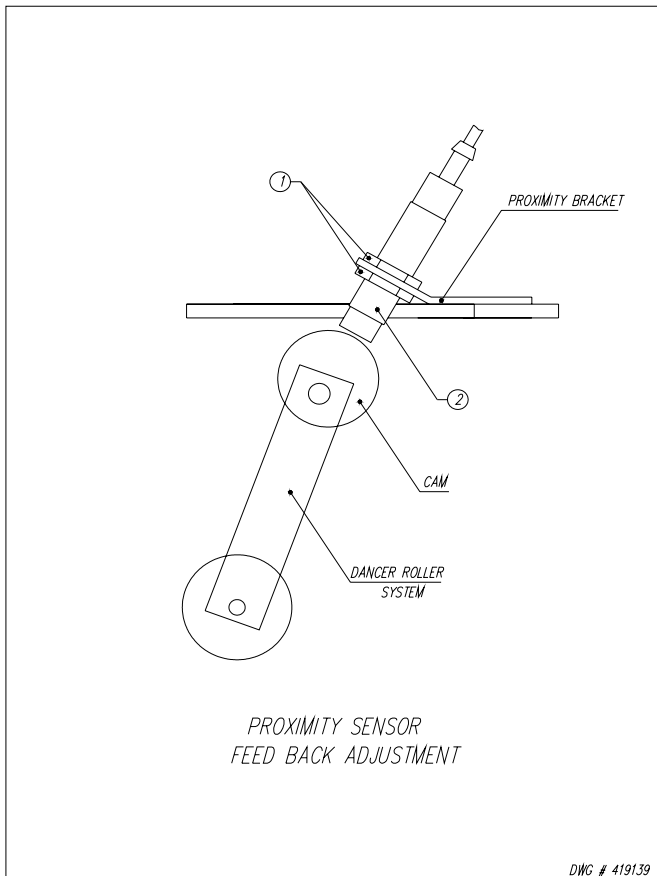

MACHINE MAINTENANCE

All general information about machine maintenance is based on normal machine working conditions: indoor, moderate dust and low moisture environment, and maximum rotation of 32 RPM of turntable/rotary arm. They should be regarded as guidelines, reviewed and corrected according to requirements of actual use and conditions.

MOTOR MAINTENANCE

An occasional inspection of the brushes should be made in order to establish a wear rate. Replacement brushes should be installed before old brushes wear to 9/16" long, measured on the long side. After replacing brushes run the motor near rated speed for at least 1/2 hour with no load to seat the new brushes. Failure to properly seat the new brushes may cause commutator damage and rapid wear of the new brushes. If the commutator becomes rough, scored or out of shape, a competent motor shop should disassemble it and resurface the commutator. With every third brush change, have a competent motor shop resurface the commutator and blow the carbon dust out of the motor.

REDUCER OIL CHANGE

All external cap screws and plugs on the reducing transmission should be checked for tightness after the first week. It is recommended to change the oil every six months or at least 1800 hours of operation, whichever comes first. When adding or changing oil, the transmission should never be filled above the oil level mark indicated, because leakage and overheating may occur. Below is the list of the type of lubricant that should be used. List of recommended reducer oils:

Manufacturer	Lubricant
American Oil Co.	American Cyl Oil no: 196-L
Cities Service Oil Co.	Citgo Cyl Oil 100-5
Gulf Oil Corp.	Gulf Senate 155
Mobil Oil Corp.	Mobil 600 W Suer-r Cyl. Oil
Philips Oil Corp.	Andes S 180
Texaco Inc.	624 + 650T Cyl.Oil
Shell Oil Co.	Velvata Oil J82
Union Oil of Cal.	Red Line Worm Gear Lube 140

RING BEARING MAINTENANCE (when applicable)

The ring bearing (located under the turntable) should be re-lubricated internally and externally.

Internally: by injecting grease into all the lubrication nipples in succession until a collar of fresh grease appears around the perimeter of the ring. The re-lubrication interval suggested for these bearings, used in Stretch Wrapping Machinery is 750 hours, with a maximum period of 6 months. The lubricant should be fresh and applied in sufficient quantities to make sure all surfaces are lubricated.

Externally: by lubricating and wiping the chain drive with oily cloth. The frequency of lubrication depends on entirely upon the usage of the machine and environment in which the machine is placed (dust, moisture etc.). Machines working under extremely dirty conditions should be lubricated every 400 operating hours but at minimum, every 2 months. Longer lubrication intervals may occur only when machine is working under very clean and dry conditions but should be not be longer than 6 months.

List of recommended lubricants for the ring bearing lubrication

Manufacturer	Lubricant
BP	Energrease LS2
Castrol	Speeroll AP2
Esso	Beacon 2
Gulf	Crown Grease 2
Mobil	Mobilus 2
Shell	Avania Grease R2
Texaco	Glissando FT 2
Valvoline	LB-2

TOWER RACEWAYS MAINTENANCE

The film distributor (carriage) is sliding on the plastic guides attached behind its back plate. The section of the tower on which the plastic guides move (raceways) should be cleaned and re-greased approximately every 600 hours of machine operation.

NOTICE: If the machine works in a dusty and corrosive environment, the raceways should be re-greased more often (at least every 100 hours).

CHAIN MAINTENANCE

To clean the chain, wipe it with an oily cloth every month. When machine is working in a dusty and damp environment, it may be necessary to repeat the cleaning operation more often. As the chain lubricants please use the most common chain lubricants on the market. With time, the chain will tend to stretch. A loose tower chain should be tightened by moving the reducer on its mounting plate. Turntable is equipped with automatic chain tensionner and does not need any adjustment.

NOTICE: First chain tension inspection must be done after the first two weeks of machine usage.

CAM FOLLOWER MAINTENANCE (when applicable)

The cam followers have deep grease pockets and do not need frequent relubrication. The portion of the tower on which the cam followers run, should be cleaned and regreased every 300 hours of operation. If the machine operates in a dusty or corrosive environment the tower should be relubricated more often.

SEMI-AUTOMATIC STANDARD ASSEMBLY PART LIST

Note :

- * Quantity listed in order of part number**
- ** The names given to the parts are generic**

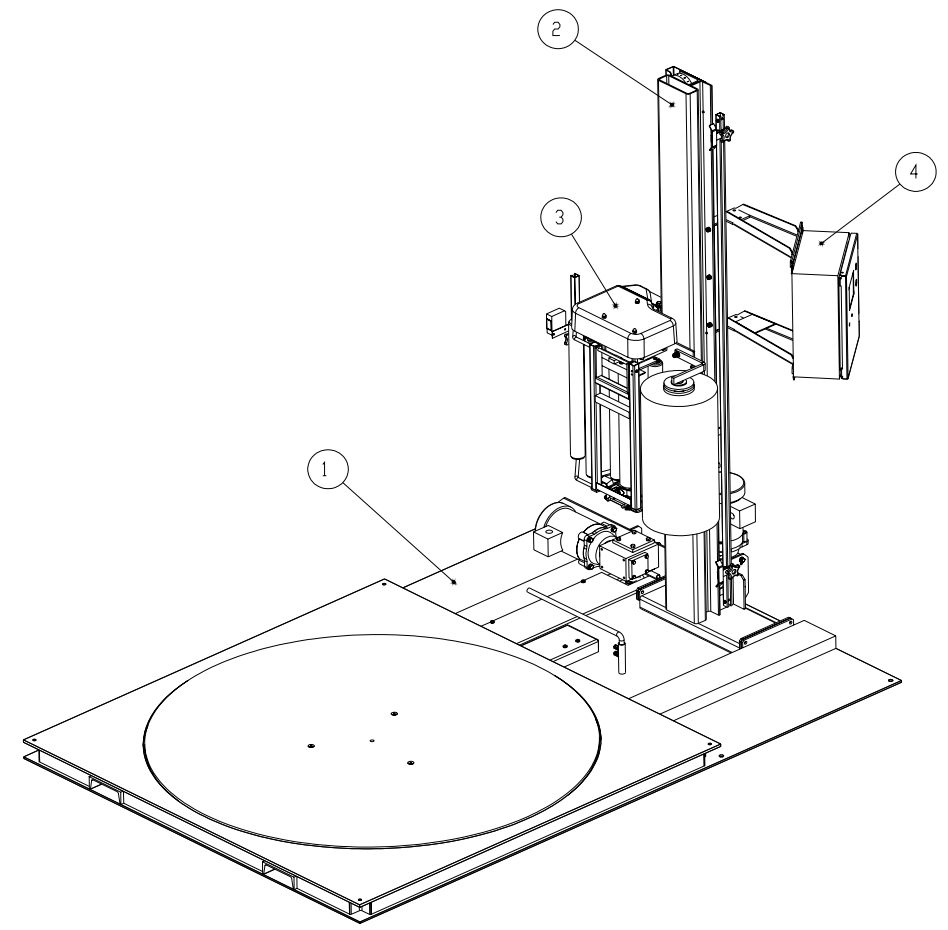
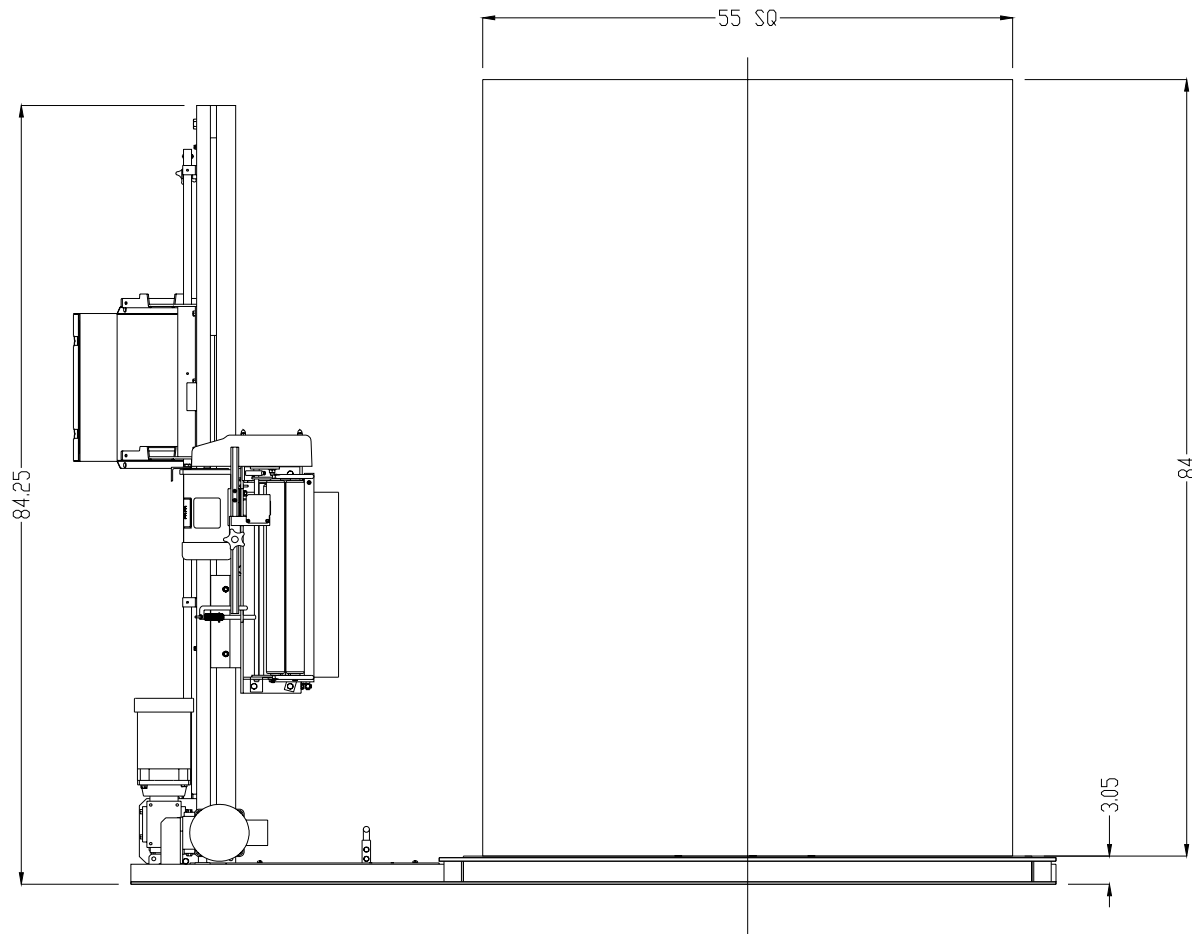
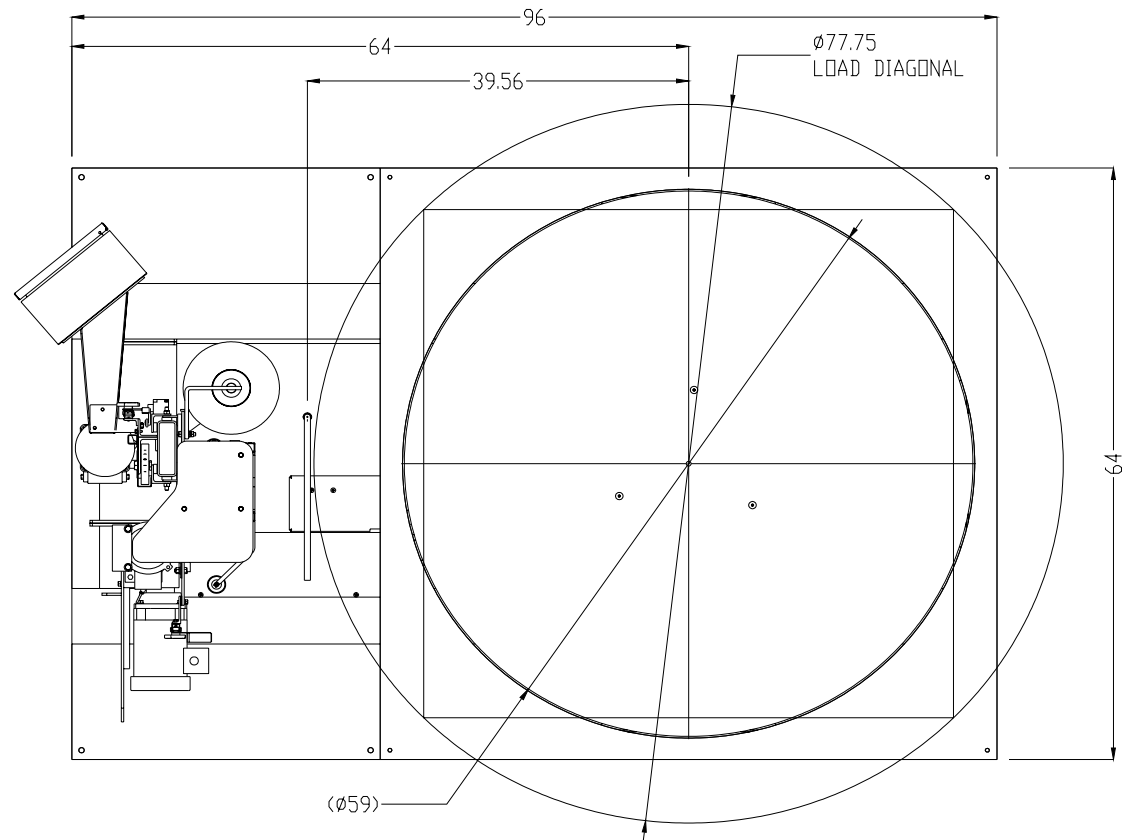

NOTE:

1. 0-12 RPM VARIABLE TURNTABLE SPEED
2. MAX LOAD SIZE 55"W X 55"L X 84"H
3. WEIGHT CAPACITY: 4,000LBS
4. POWER REQUIREMENT: 115/1/60 15 AMP SERVICE
5. MACHINE COLOR: 2-TONE ORION STD GREY (PLATINUM GREY & DARK GREY)
6. 20" INSTA-THREAD FILM CARRIAGE
7. 0 59" DIA STRUCTURAL STEEL PLATE

#	TITLE	Length	PART NO	Q
4	ENCLOSURE 16' x 12' x 6'		016274	1
3	20" INSTA-THREAD "E" ASSEMBLY (FRL)		438647	1
2	HINGE TOWER 6 x 2 - ASS'Y (STANDARD)		449422-00	1
1	L77/20 S BASE ASSEMBLY (STANDARD)		449449-00	1

REMARKS				
REMARKS				
L77S-20 LAYOUT - ASSEMBLY				
<p>ORION PACKAGING INC. 2270 INDUSTRIEL, LAVAL QUEBEC, CANADA, H7S 1P9 TEL: (450) 667-9769</p>	<p>TOLERANCES UNLESS OTHERWISE SPECIFIED</p> <p>MACHINER - 1/164 WELDED - 1/162 ANGLE - 1/162 XXX - 1/162 XXXX - 1/162 REFERENCE DWG</p>	<p>DRAWN BY G.PETRAZZUOLI</p>	<p>DRAWN DATE OCT/26/2006</p>	<p>WEIGHT (lb) 2176.42</p>
		<p>APPROVED BY</p>	<p>APPROVED DATE</p>	<p>SCALE 1:20</p>
<p>MACHINE TYPE L77S-20</p>		<p>JOB NO. STD</p>	<p>SHEET 1 / 1</p>	<p>REV. A+</p>
<p>ASSEMBLY DWG</p>		<p>DWG SIZE B</p>	<p>DWG NO. 449245M</p>	<p>REV. A+</p>

CE DESSIN EST CONFIDENTIEL ET NE DOIT PAS ETRE REPRODUIT OU UTILISE SANS LE CONSENTEMENT DES EMBALLAGES ORION INC.

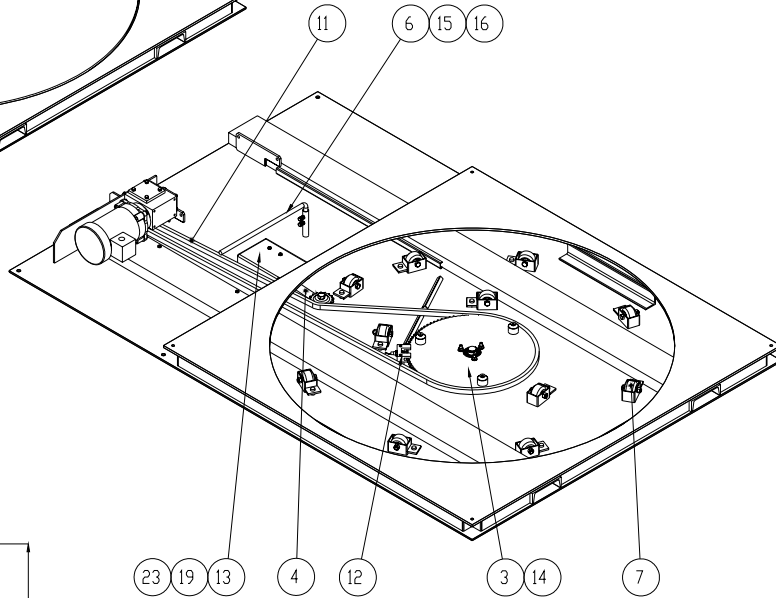
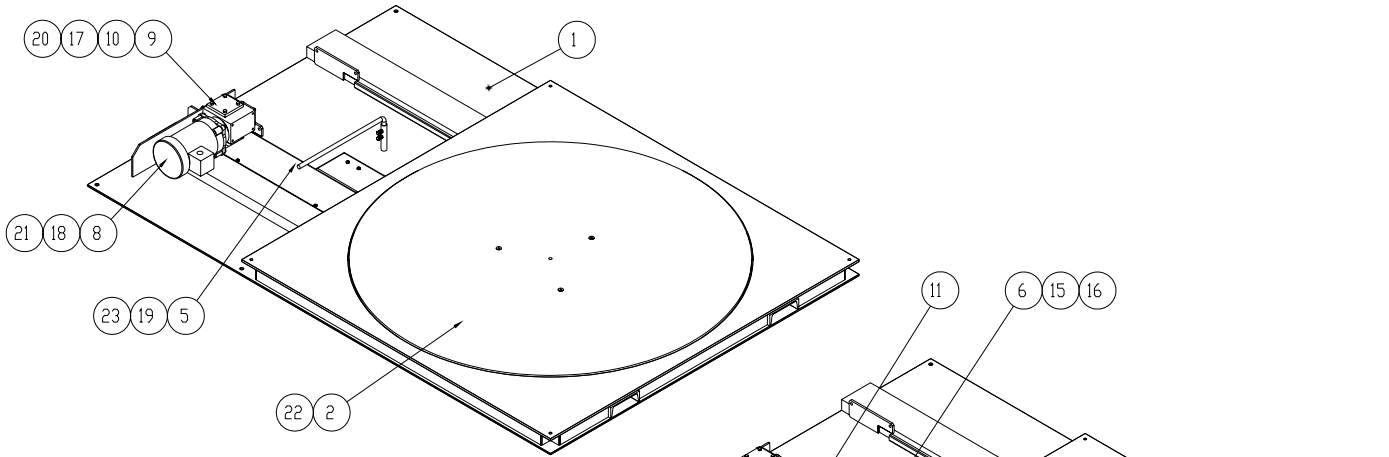

2X Ø 13/64" ± 13/64"
 1/4-20UNC - 2B ± 13/64"
 DRILL AND TAP CHANNEL
 WITH GUARD AS A GUIDE

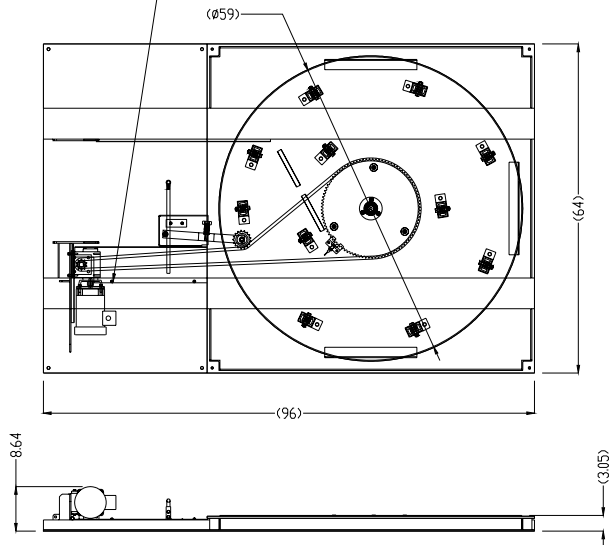

23	PAN PHILIPS HEAD SCREW 1/4-20NC x 3/4"		016591	4
22	SOCKET FLAT HEAD SCREW 3/8-24NF x 1"		013842	3
21	LOCK WASHER 3/8"		011390	4
20	LOCK WASHER 5/16"		012724	4
19	LOCK WASHER 1/4"		011393	4
18	HEX BOLT 3/8-16NC x 1 1/4"		012406	4
17	HEX BOLT 5/16-24NF x 1"		015072	4
16	HEX BOLT 5/16-24NF x 3/4"		017400	2
15	HEX NUT 5/16-24NF		013407	2
14	EXTERNAL RETAINING RING - 1 1/4" SIZE		013655	1
13	TIGHTENER GUARD		449115	1
12	TURNTABLE DRIVE PROXIMITY ASS'Y		442303	1
11	CHAIN #50, 243 LINKS + C/L	152 1/2"	010009	1
10	SPROCKET 50B10, 7/8" BORE		010074	1
9	REDUCER CFC-175, 15:1, RIGHT, 56C		015191	1
8	EL. MOTOR 1/2HP, 208-230/460VAC, 1725 R.P.M.		015225	1
7	"DURA-GLIDE" CASTER 2.33"Ø ASSEMBLY		416055	11
6	RODING BAR	23 1/8"	413868	1
5	CHAIN GUARD (STANDARD)	25 7/8"	421447-00	1
4	CHAIN TIGHTENER ASSEMBLY		441083	1
3	TURNTABLE DRIVE SPROCKET ASS'Y		442302	1
2	59" DIA. TURNTABLE DISK (REVOLGIC)		414904	1
1	L66/20 & L77/20 S BASE - WELDING (STANDARD)		449424-00	1
#	TITLE	Length	PART NO	Q

REMARKS					
L77/20 S BASE ASSEMBLY (STANDARD)					
		TOLERANCES UNLESS OTHERWISE SPECIFIED FINISHES UNLESS OTHERWISE SPECIFIED	DRAWN BY K. TRAN	CHECK DATE OCT/30/2006	WEIGHT 1773.41
APPROVED BY [Signature]	APPROVED DATE [Date]	SCALE 1:18	JOB NO. STD	SHEET 1/1	REV A
MACHINE TYPE L77/20 S	ASSEMBLY PWC 449245	DWG SIZE B	DWG NO. 449449-00M		

CE DESSIN EST CONFIDENTIEL ET NE DOIT PAS ETRE REPRODUIT OU UTILISE SANS LE CONSENTEMENT DES EMBALLAGES BRITON INC.

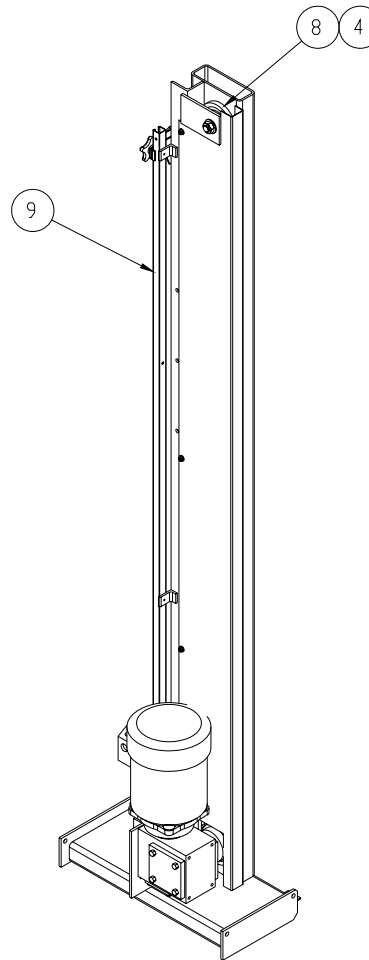
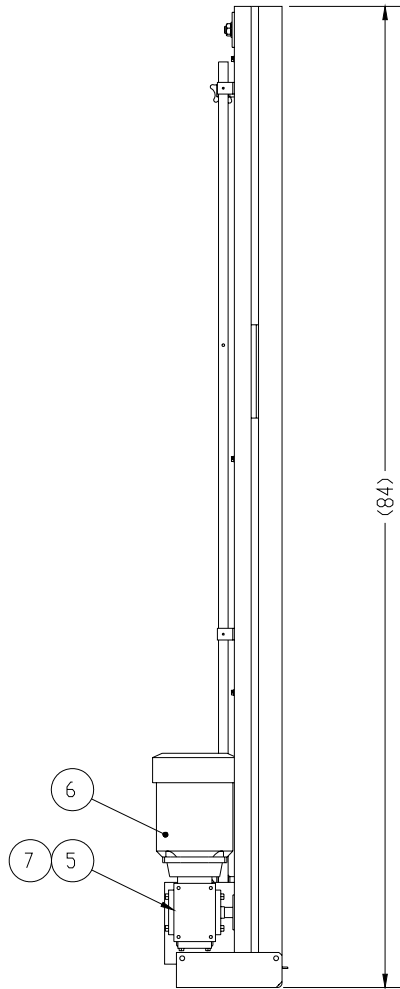
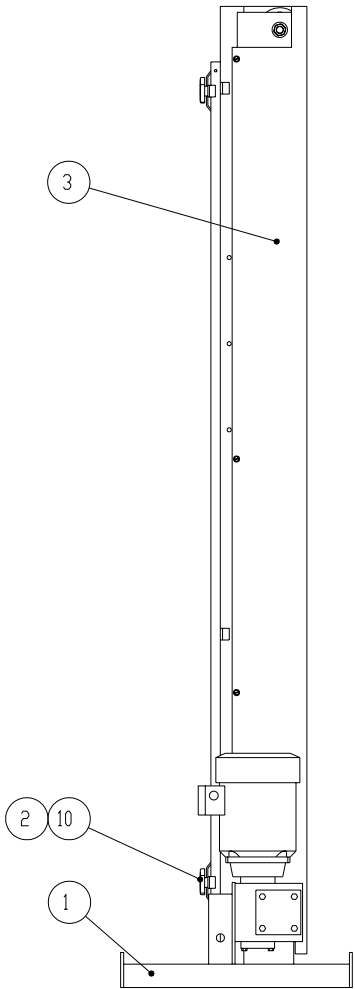
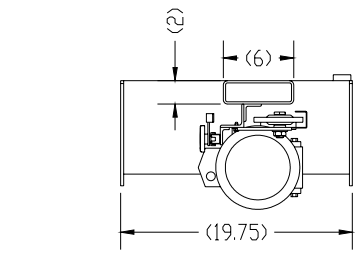

17	SLOTTED HEX HEAD THREAD FORMING SCREW 1/4-20NC x 1/2"		016142	3
16	SEALING WASHER 3/4" #185.585		010695-3	1
15	NUT LOCK 3/4" #186.854		010695-2	1
14	PLASTIC CONNECTOR 3/4" #186.803		010695-1	1
13	SEALING WASHER 1/2"		010650-3	1
12	NUT LOCK 1/2"		010650-2	1
11	PLASTIC CONNECTOR 1/2"		010650-1	1
10	KNOB W/ THREADED BLIND HOLE 3/8-16NC		010092	2
9	CHANNEL P-6000, STD TOWER HEIGHT	76"	428965-00	1
8	CHAIN #50 (253 LINKS + 2 C/L)	159 3/8"	010009	1
7	SPROCKET 50B19, 7/8" BORE		010235	1
6	EL. MOTOR 1/2HP, 208-230/460VAC, 1725RPM		015225	1
5	REDUCER CFC-175, 50:1, RIGHT, 56C		015200	1
4	IDLER SPROCKET ASSEMBLY		420809	1
3	CHAIN GUARD, STANDARD TOWER HEIGHT	81 1/8"	428968-00	1
2	STRIKER ASS'Y		427691	2
1	HINGE TOWER 6 x 2 - WELDING		449421	1
#	TITLE	Length	PART NO	Q

REMARKS				
HINGE TOWER 6 x 2 - ASS'Y (STANDARD)				
 ORION PACKAGING INC. 2270 INDUSTRIAL LAVAL BUREAU, CANADA H7S 1P2 TEL: (450) 667-9769	TOLERANCES UNLESS OTHERWISE SPECIFIED	DRAWN BY G.PETRAZZUOLI	DRAWN DATE OCT/26/2006	WEIGHT GROSS 197.85
	MACHINED - 1/64 MILLED - 1/32 ANGLE - 1/8" 3/16" MIN XXXX - NONE REFERENCE DWG	APPROVED BY	APPROVED DATE	SCALE 1:12
	MACHINE TYPE H/L77-20	ASSEMBLY DWG	PAGE SIZE B	DWG NO 449422-00

CE DESSIN EST CONFIDENTIEL ET NE DOIT PAS ETRE REPRODUIT OU UTILISE SANS LE CONSENTEMENT DES EMBALLAGES ORION INC.

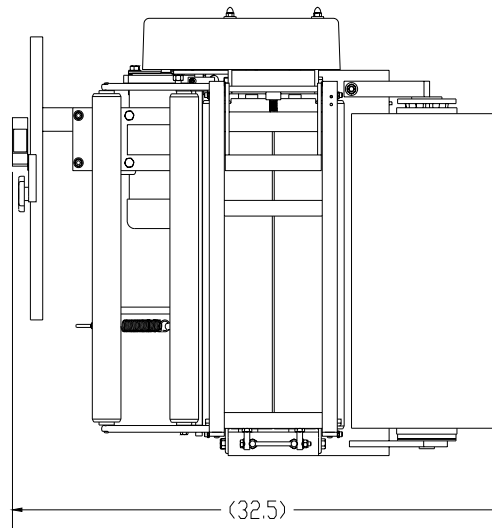
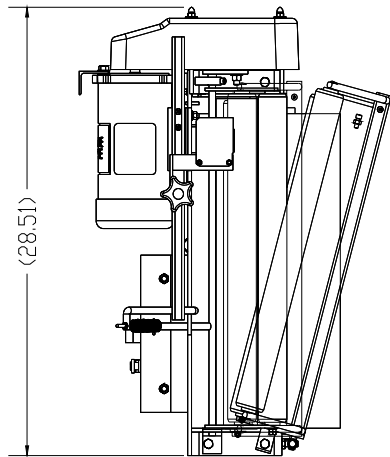
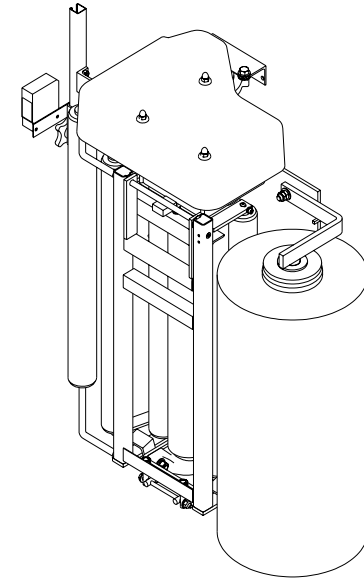
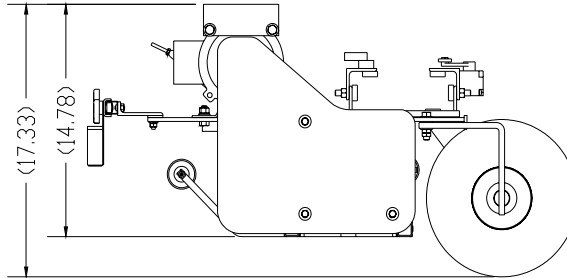
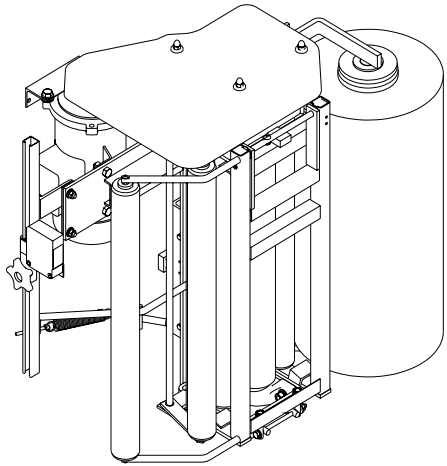

CE DESSIN EST CONFIDENTIEL ET NE DOIT PAS ETRE REPRODUIT OU UTILISE SANS LE CONSENTEMENT DES EMBALLAGES ORION INC.

REMARKS 6 x 2 HINGE TOWER, DARK GREEN MOTOR				
REMARKS 17' VERSION ONLY - H AND L 77 MACHINE				
20" INSTA-THREAD "E" ASSEMBLY (FRL)				
 ORION PACKAGING INC. 2270 INDUSTRIEL LAVAL QUEBEC, CANADA, H7S 1P9 TEL: 450 667-9169	TOLERANCES UNLESS OTHERWISE SPECIFIED	DRAWN BY S.KUBICKA	ISSUE DATE 07/02/2003	WEIGHT (KG) 162.79
	WALDERS - 1/16"	APPROVED BY	APPROVED DATE	SCALE 1:10
	WELDS - 1/32"	MACHINE TYPE H, L 77/17	JOB NO.	SHEET 1 / 2
	ANGLE - 1/32" 60° X3X - 1/32" X4X - 1/32" REFERENCE DWG.	ASSEMBLY DWG	DWG SIZE B	DWG NO. 438647M

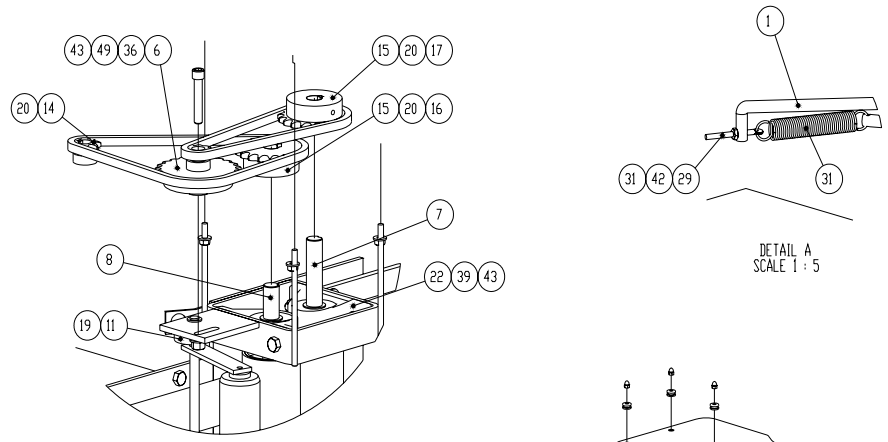
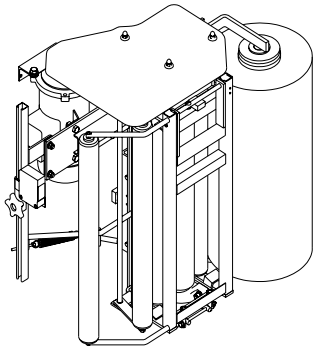

DETAIL B
SCALE 1:6

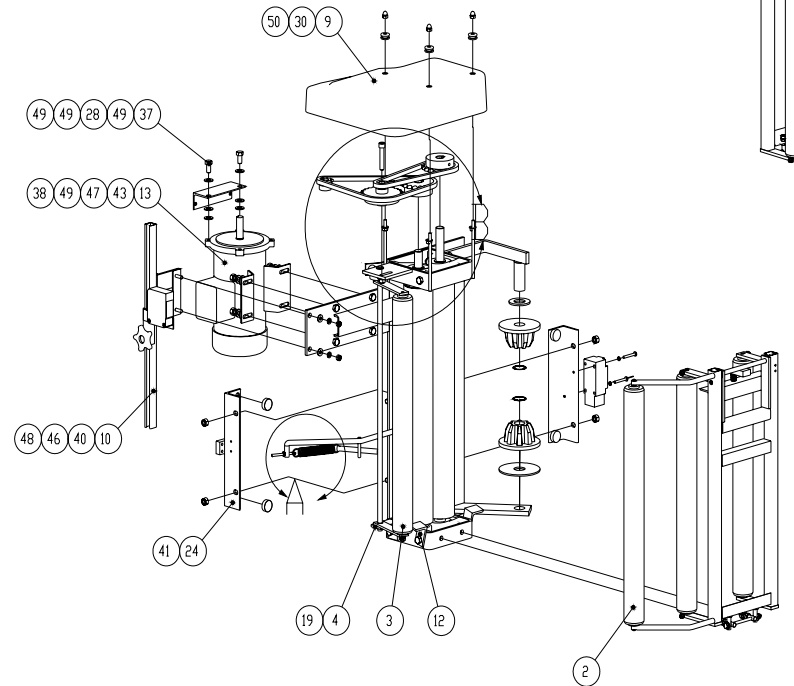
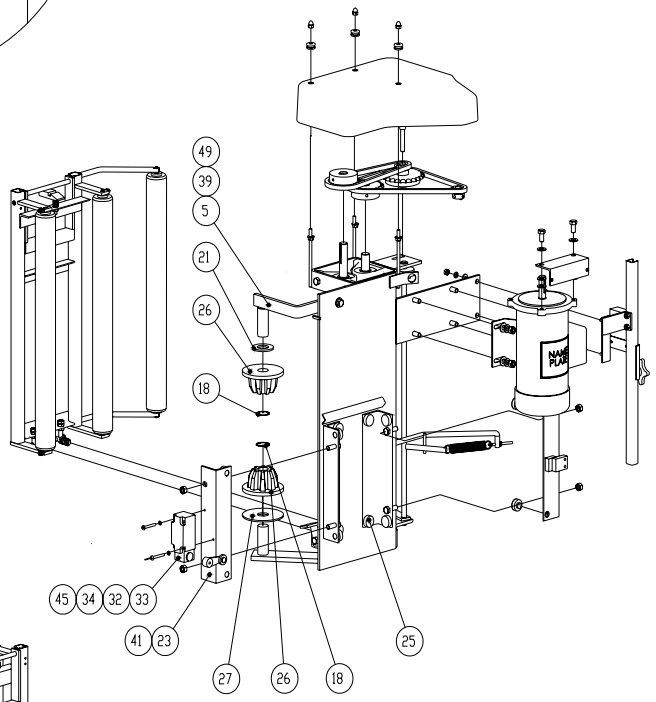

50	HEX CAP NUT 1/4-20NC		014195	3
49	FLAT WASHER 3/8"		010948	22
48	FLAT WASHER 1/4"		012221	5
47	LOCK WASHER 3/8"		011390	12
46	LOCK WASHER 1/4"		011393	2
45	LOCK WASHER #10		013444	2
44	HEX NUT 3/8-16NC		015121	2
43	HEX NUT 3/8-16NC		011128	13
42	NYLON INSERT LOCKNUT #10-32NF		018434	1
41	HEX NUT 3/8-24NF		012582	4
40	HEX NUT 1/4-20NC		012689	5
39	HEX BOLT 3/8-16NC x 1 1/2"		012476	9
38	HEX BOLT 3/8-16NC x 1"		010293	4
37	HEX BOLT 3/8-16NC x 3/4"		012474	2
36	SOCKET HEAD CAP SCREW 3/8-16NC x 2"	2"	012686	1
35	SOCKET HEAD CAP SCREW 1/4-20NC x 1/2"		010257	1
34	PAN PHILIPS HEAD SCREW #10-24NC x 1 1/2"		012858	2
33	LIMIT SWITCH ZCKJ404		015118	1
32	LEVER ZCKY13		015215	1
31	YELLOW TENSION SPRING 3/4"OD x 0.080" WIRE		010047	1
30	GRODMET 5/16 ID x 9/16 GROOVE DIA x 3/16 GROOVE W		014502	3
29	TENSION SCREW		433629	1
28	CARRIAGE JUNCTION BDX BRACKET	5"	426059	1
27	BOTTOM SPOOL WASHER		432322	1
26	BOTTOM SPOOL		432323	2
25	SLIDE BUTTON	17/32"	427058	12
24	CARRIAGE CHAIN ATTACHMENT ANGLE ASS'Y (5 X 2 TOWER)		420000	1
23	CARRIAGE ATTACHMENT ANGLE (2' - THK TOWER)	10"	419999	1
22	PILLOW BLOCK BEARING UCP 204-12, 3/4" BORE		011192	4
21	FLAT WASHER 1"		017327	1
20	SQ. KEY STOCK 3/16" x 3/16"	1"	010295	3
19	DIL. BR FLANGE BUSHING 7/16 ID x 9/16 OD x 1/2 LG		014247	2
18	SEFT SEATING RETAINING RING 1/2 SIZE R6100-100		013860	2
17	CHAIN #40, MADE IN JAPAN, 43L + C/L	22"	013397	1
16	CHAIN #40, MADE IN JAPAN, 55L + C/L	27 1/2"	013397	1
15	SPROCKET 40B20, 3/4" BORE		011454	2
14	SPROCKET - 40B8 x 5/8" BORE (REVISED)		415109	1
13	EL. MOTOR 1/2HP, 90VAC, 1725RPM		019134	1
12	CRADLE ROLLER OPENING LDCX	1"	409469	2
11	PROXIMITY SENSOR CAM	1/2"	413744	1
10	PHOTOCELL ASS'Y 20" CARRIAGE (FRL)		436361-20	1
9	FIBERGLASS COVER		414305	1
8	ECONOMIC RUBBER ROLLER - 2 (20" FILM)		433904-20	1
7	ECONOMIC RUBBER ROLLER - 1 (20" FILM)		433903-20	1
6	DOUBLE SPROCKET (40B8/40B24) ASS'Y		414546	1
5	TOP MANDREL (FRL)		414193	1
4	DANCER ROLLER BRACKET (FRL)	1 1/4"	413745	1
3	DANCER ROLLER ASS'Y - 20(FRL)		414194	1
2	CRADLE ROLLER ASSEMBLY - 20 (FRL)		422327	1
1	20" BACK PLATE - FRL		433854	1
#	TITLE	Length	PART NO	0

REMARKS
6 x 2 HINGE TOWER, DARK GREEN MOTOR
17 VERSION ONLY - H AND L 77 MACHINE

20" INSTA-THREAD "E" ASSEMBLY (FRL)		DATE	WEIGHT (G)
ORION PACKAGING INC. 2278 BRIDGEVIEW LANE DORSET, CANADA N7S 1P9 TEL: (416) 667-9166	TOLERANCES UNLESS OTHERWISE SPECIFIED FRACTIONS - 1/64 DECIMALS - 0.005 ANGLES - 0.5° DIM. - 0.01 TYP. - 0.005	DRAWN BY SKUBICKA APPROVED BY DATE	DATE 07/02/2003 SCALE 1:12 SHEET 2 / 2
REFERENCE ENG	ASSEMBLY ENG	DWG SIZE	DWG NO 438647
		B	REV B

CE Dessin est confidentiel et ne doit pas être reproduit ou utilisé sans le consentement des Emballages Orion Inc.

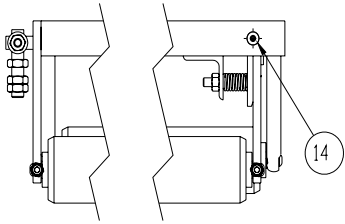

SECTION A-A
SCALE 1:4

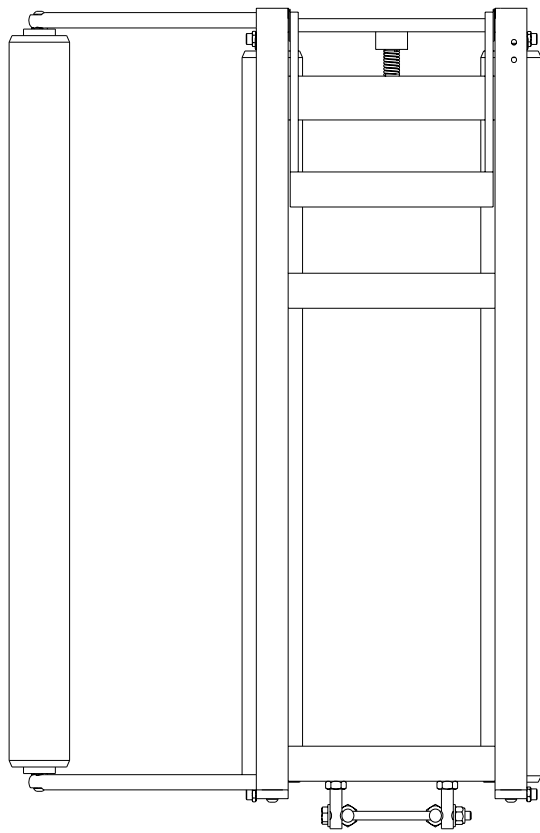
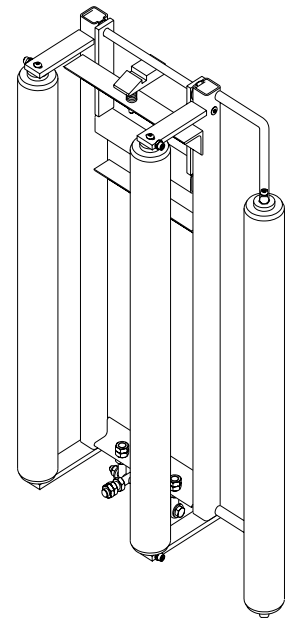
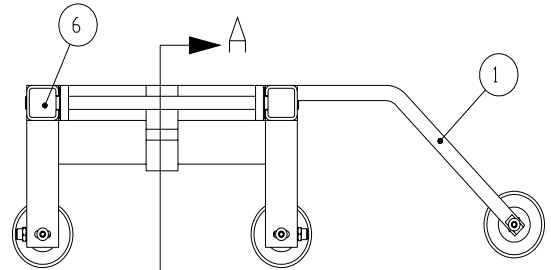

BACK VIEW

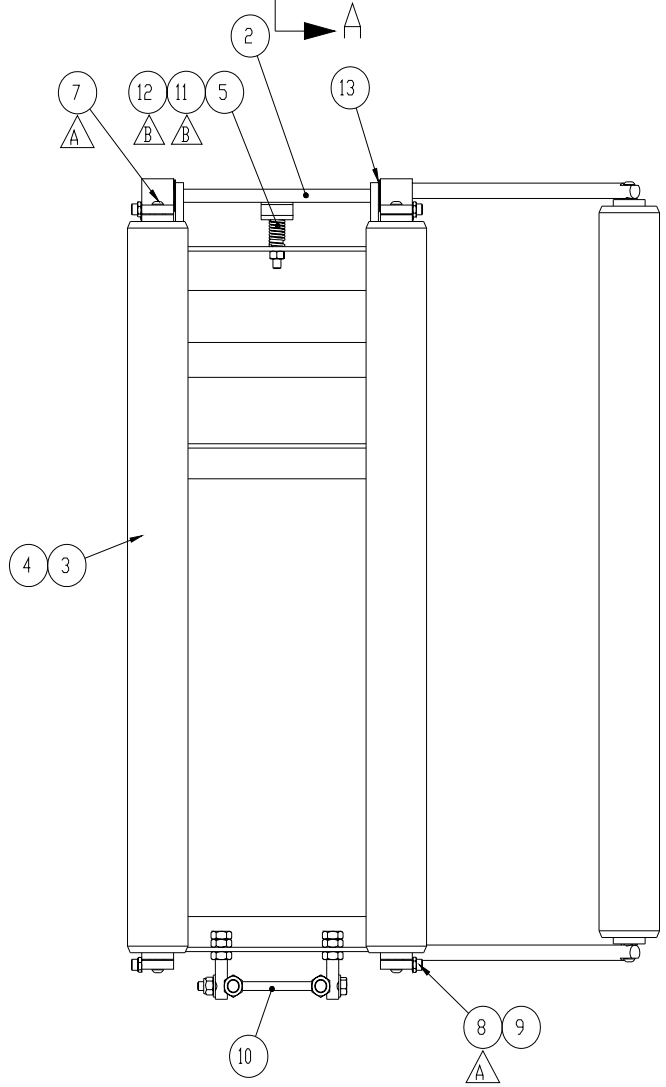

14	POP RIVET		015534	2
13	THRUST WASHER		013144	2
12	HEX NUT		013048	1
11	SOCKET HEAD CAP SCREW		017957	1
10	CRADLE HINGE ASS'Y		426200	1
9	HEX NUT		013451	4
8	SOCKET HEAD CAP SCREW		014002	4
7	BUTTON SOCKET CAP SCREW		015133	6
6	POLYETHYLENE INSERT		431158	2
5	SPRING		013994	1
4	IDLE ROLLER SHAFT		413249	3
3	CONVEYOR ROLLER "INTERROLL"		402789	3
2	LOCK		412542	1
1	CRADLE ROLLER FRAME - 20"		422328	1
#	TITLE	Length	PART NO	Q

REMARKS

CRADLE ROLLER ASSEMBLY - 20 (FRL)

 ORION PACKAGING INC. 2270 INDUSTRIEL L'AVANT DREXEL-CAMAR, HYS 1P3 TEL: (450) 667-9169	TOLERANCES UNLESS OTHERWISE SPECIFIED	DRAWN BY SKUBICKA	DRAWN DATE 12/15/1999	WEIGHT (LBS) 15.30
	APPROVED BY	APPROVED DATE	SCALE 1:6	SHEET 1 / 1
MACHINE TYPE H, L TYPE	JOB NO. STD	ENG SIZE B	ENG NO. 422327	REV. C
REFERENCE DWG 422047	ASSEMBLY DWG	DWG NO. B	PART NO. 422327	QTY. 1

CE Dessin EST CONFIDENTIEL ET NE DOIT PAS ETRE REPRODUIT OU UTILISE SANS LE CONSENTEMENT DES EMBALLAGES ORION INC.

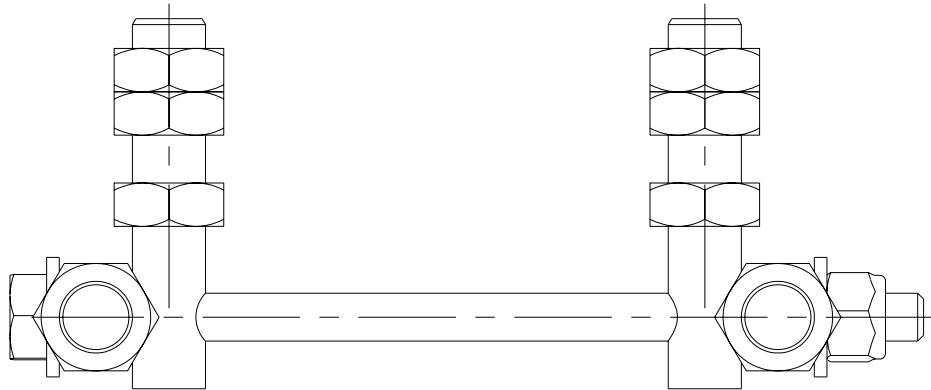
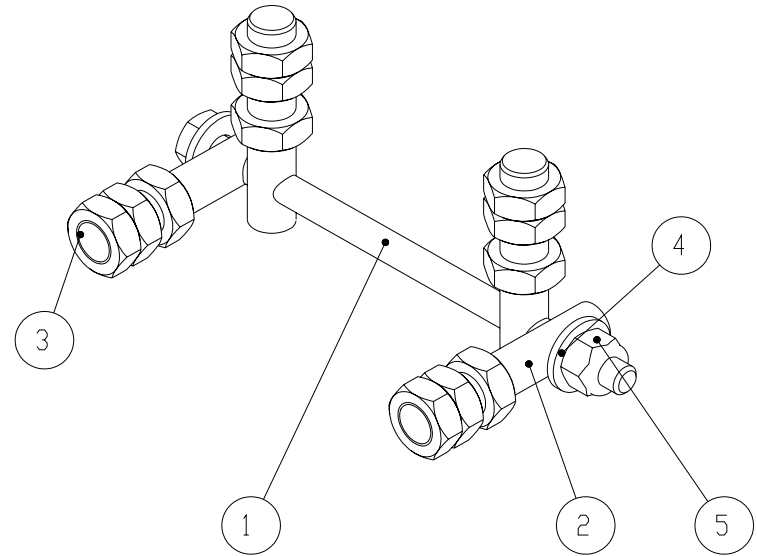
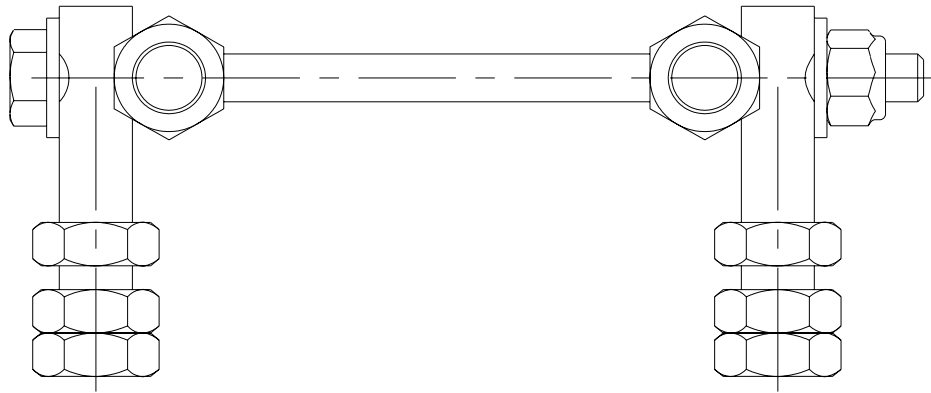

#	TITLE	Length	PART NO	Q
5	HEX. SELF-LOCKING NUT		015098	1
4	FLAT WASHER		012221	2
3	HEX. JAM NUT		014235	12
2	SPECIAL BOLT		415938	4
1	HEX BOLT		015099	1

REMARKS

REMARKS

CRADLE HINGE ASS'Y

 <p>ORION PACKAGING INC. 2270 INDUSTRIEL, LAVAL QUEBEC, CANADA, H7S 1P9 TEL: (450) 667-9769</p>	<p>TOLERANCES UNLESS OTHERWISE SPECIFIED</p> <p>MACHINED : ±1/32 WELDED : ±1/16 ANGLE : ±1/16 XXX : ±0.02 XXXX : ±0.005</p>	<p>DRAWN BY S.KUBICKA</p> <p>APPROVED BY</p>	<p>DRAWN DATE 12/15/1999</p> <p>APPROVED DATE</p>	<p>WEIGHT (lb) 0.45</p>
	<p>MACHINE TYPE ALL</p> <p>REFERENCE DWG</p>	<p>JOB NO.</p> <p>ASSEMBLY DWG</p>	<p>SHEET 1 / 1</p>	<p>DWG NO. 426200M</p>

CE DESSIN EST CONFIDENTIEL ET NE DOIT PAS ETRE REPRODUIT OU UTILISE SANS LE CONSENTEMENT DES EMBALLAGES ORION INC.

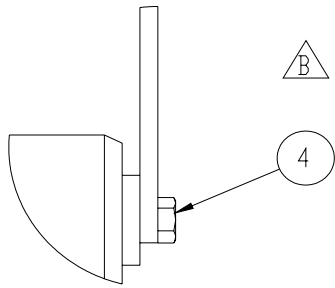
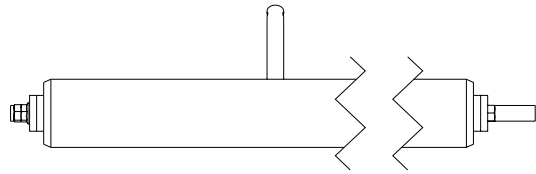
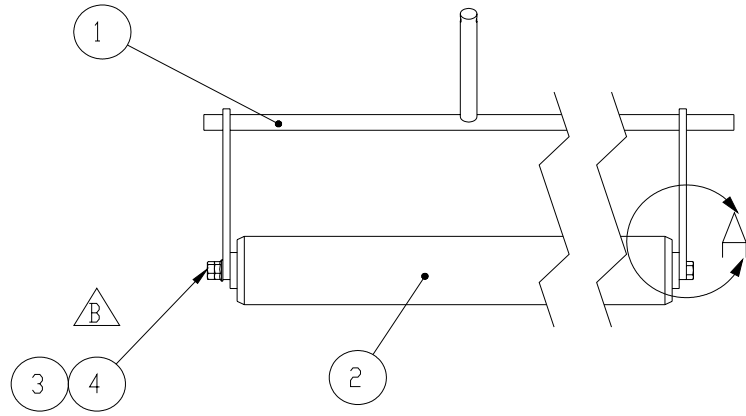

DETAIL A
SCALE 1 : 2

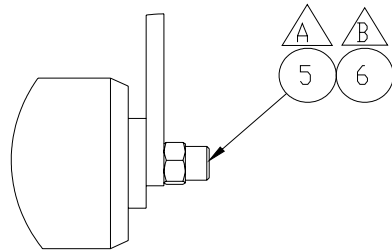

DETAIL A (S-SENSE)
SCALE 1 : 2

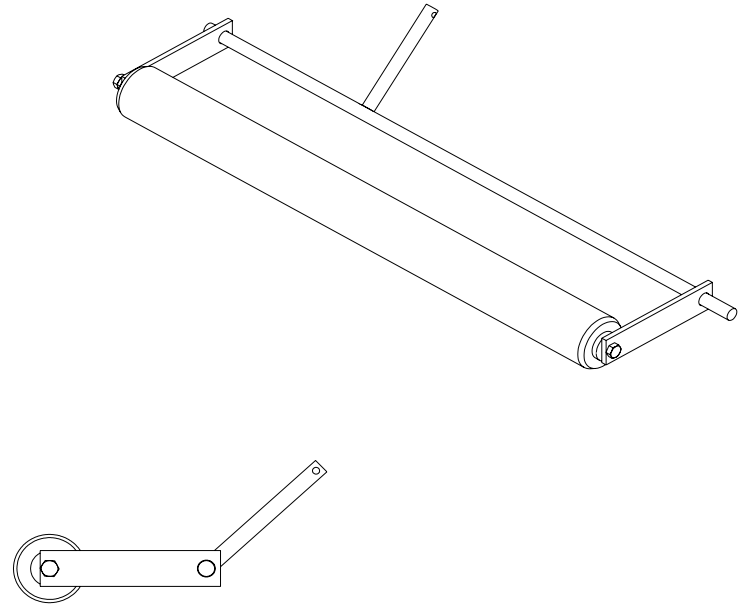

6	HEX NUT		012689	-
5	SOCKET HEAD CAP SCREW		010259	-
4	HEX BOLT		013989	2
3	HEX FLANGE NUT		014164	1
2	CONVEYOR ROLLER		402789	1
1	DANCER ROLLER CRADLE		414195	1
#	TITLE	Length	PART NO	Q

REMARKS

REMARKS

DANCER ROLLER ASS'Y - 20(FRL)

<p>ORION PACKAGING INC. 2270 INDUSTRIEL, LAVAL QUEBEC, CANADA, H1S 1P9 TEL: (450) 667-9769</p>	<p>TOLERANCES UNLESS OTHERWISE SPECIFIED</p> <p>MACHINED : ±1/32 WELDED : ±1/16 ANGLE : ±1/16 XXX : ±0.02 XXXX : ±0.005</p>		<p>DRAWN BY ROGER F.</p>	<p>DRAWN DATE 09/17/1999</p>	<p>WEIGHT (lb) 3.43</p>
	<p>APPROVED BY</p>		<p>APPROVED DATE</p>	<p>SCALE 1:5</p>	<p>SHEET 1 / 1</p>
	<p>PER 60° MACHINE TYPE ALL TYPE</p>		<p>JOB NO. STD</p>	<p>DWG NO. 414194M</p>	
<p>REFERENCE DWG</p>	<p>ASSEMBLY DWG 414189</p>	<p>DWG SIZE A</p>	<p>REV. A+</p>		

CE DESSIN EST CONFIDENTIEL ET NE DOIT PAS ETRE REPRODUIT OU UTILISE SANS LE CONSENTEMENT DES EMBALLAGES ORION INC.

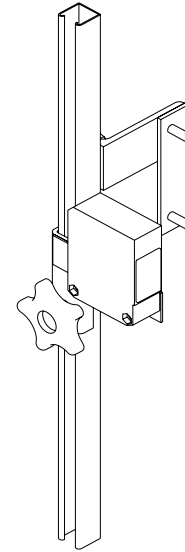
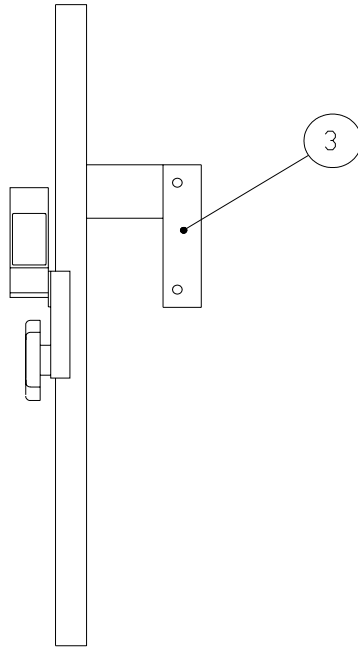
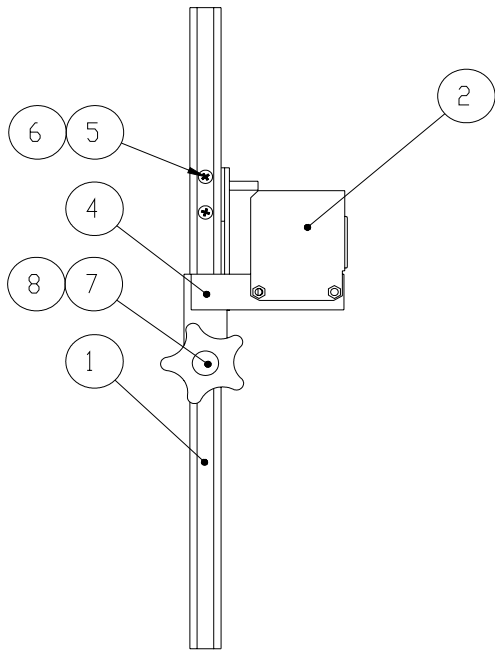
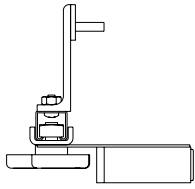

8	HEX NUT 1/4-20NC		012689	2
7	FLAT SQUARE NUT 3/8-16NC		017853	1
6	KNOB W/ THREADED BLIND HOLE 3/8-16NC		010092	1
5	PAN PHILIPS HEAD SCREW #10-24NC x 1/2"		012481	2
4	PHOTOCELL HOLDER (FLR)		436362	1
3	PHOTOCELL CHANNEL BRACKET (FRL)		429653	1
2	PHOTOCEL CHANNEL P-6000, 20" CARRIAGE	18"	429285-20	1
1	PHOTOCELL DIFFUSE, WT 260-R 280 (SICK)		017303	1
#	TITLE	Length	PART NO	0

REMARKS

FOR INSTA-THREAD CARRIAGE

PHOTOCELL ASS'Y 20" CARRIAGE (FRL)

<p>ORION PACKAGING INC. 2270 INDUSTRIEL, LAVAL QUEBEC, CANADA, H7S 1P9 TEL: (450) 667-9769</p>	TOLERANCES UNLESS OTHERWISE SPECIFIED	DRAWN BY M.G. GOLLA	DRAWN DATE 10/09/2002	WEIGHT (lb) 1.599	
	MACHINED : ±1/32 WELDED : ±1/16 HOLE : ±1/16 XXX : ±0.02 XXXX : ±0.05 REFERENCE DWG.	APPROVED BY	APPROVED DATE	SCALE 1:5	
	MACHINE TYPE H/L TYPE	JOB NO STD	SHEET 1/1		
	ASSEMBLY DWG	DWG SIZE A	DWG NO 436361-20	REV. B+	

INC. CE DESSIN EST CONFIDENTIEL ET NE DOIT PAS ETRE REPRODUIT OU UTILISE SANS LE CONSENTEMENT DES EMBALLAGES ORION

